

Media Information

June 25, 2015.

Two strong: introducing the all-new BMW X5 M and all-new BMW X6 M.

Innovative technology and a powerful presence.

Jakarta - BMW Group Indonesia is today introducing the all-new BMW X5M and all-new BMW X6 M, both of which offer proof that M is still the most powerful letter in the world. With these two powerful models, BMW M is setting the pace once again in the high-performance Sports Activity Vehicle (SAV) and Sports Activity Coupé (SAC) segments. When the previous generation of these two vehicles arrived in 2009, it was the first time the high-performance character distilled by BMW M had been transplanted into an all-wheel-drive BMW X model. The result was class-leading dynamics.

“The all-new BMW X5 M and BMW X6 M combine the characteristic features of the successful BMW X family – exclusivity, robustness, agility and everyday usability – with the commitment to high performance that defines an M car,” said Karen Lim, President Director BMW Group Indonesia. “With these new models, BMW Indonesia is ready to write the next chapter in its story of success, providing another significant step forward in dynamic excellence, emotionally rich BMW M design and outstanding efficiency,” added Karen.

For BMW M, high performance is about more than engine output and top speeds alone. High performance pertains more to all of a vehicle’s components working in perfect harmony, and the precise interplay of various details resulting in maximum performance, agility, precision, poise and assurance out on the road. This sense of balance is a defining feature of all the vehicles produced by BMW M and is, needless to say, also present in the all-new BMW X5 M and BMW X6 M.

Excellent dynamics before a wheel has turned.

The outstanding driving dynamics of the all-new BMW X5 M and new BMW X6 M are also prominent through their M design signatures. The close ties between the two models – they have identical performance levels and equally strong dynamic potential – are reflected very clearly in the shared design of the front end with its large air intakes. However, the individual

characters of the two high-performance sports models are still very distinct. This becomes clear the first time they come into view.

The all-new BMW X5 M fulfills the full power potential of BMW M models, while it also offers the versatility of X5 models. The Sports Activity Vehicle is designed as an M model, which means a powerful presence, multitalented sportiness and maximum driving pleasure. This new model is a fully-fledged BMW M with all-wheel drive – an impressively attractive blend of functionality and motor sport.

The all-new BMW X6 M is the self-contained, extrovert result of a blend between an athletic coupé and the motor sport DNA of a BMW M vehicle in an X model. Combining expressive sports car technology with the emotional design language of X Coupés, the design of this new model represents a statement of independence and ensures this ultimate Sports Activity Coupé exudes athleticism.

A visually striking front end with a functional task.

The large air intakes and big “kidneys” of the radiator grille, with their customary BMW M double-bar look, are a response to the high air-cooling requirements of the powerful engine, transmission and high-performance front brakes. Despite the large amount of cooling and more stringent pedestrian protection requirements, the designers have managed to integrate foglamps into the front end of the vehicles. Both new M models borrow their headlights from the BMW X6, complete with a washer system. Elsewhere, the special flaps low down in the outer air intakes –adapted from those on racing cars – reduce lift and emphasise the optimised aerodynamics of the two new models.

Same genes, distinctive looks.

The differences in the characters of the all-new BMW X5 M and BMW X6 M are very evident when the two models are viewed from the side. The all-new BMW X5 M reinforces its presence and functionality with its upright stature, long roofline and large window surfaces. By contrast, the all-new BMW X6 M displays the unmistakable, dynamic lines of a BMW Sports Activity Coupé through its gently curved glasshouse, sloping roofline and pronounced wedge shape. M-specific features of both models include the familiar twin-stalk exterior mirrors with integral

side indicators. Another signature element of BMW M are the gills in the front side panels featuring chrome trim that includes the Air Breather with M badge.

The new M TwinPower Turbo Engine: V8 with even more torque, backed by an emotionally rich soundtrack.

The all-new BMW X5 M and BMW X6 M are powered by the new BMW M TwinPower Turbo engine, which is the most powerful unit ever developed by BMW for an all-wheel-drive vehicle. Boasting innovative BMW M TwinPower Turbo technology with a pair of TwinScroll turbochargers, cross-bank exhaust manifolds, VALVETRONIC and High Precision Direct Petrol Injection, the 4.4-litre V8 produces maximum output of 575 hp between 6,000 and 6,500 rpm. That represents a four percent increase over the predecessor models. The step up is even clearer when it comes to the power development of the new engine. Peak torque has been boosted by 70 Nm, which equates to a rise of 10 percent. Its 750 Nm can be enjoyed across a broad rev range between 2,200 and 5,000 rpm.

At the same time, fuel consumption of the all-new BMW X5 M and BMW X6 M in the EU cycle has been cut by 20 per cent CO₂ emissions are likewise reduced by more than 20 percent, to 258 g/km. The two models accelerate from 0 to 100 km/h in just 4.2 seconds through the eight-speed M Steptronic transmission with Drivelogic, while top speed is limited to 250 km/h.

Eight-speed M Steptronic transmission with Drivelogic.

The all-new BMW X5 M and new BMW X6 M send their engine power to the wheels via the newly developed eight-speed M Steptronic transmission with Drivelogic, which mirrors the operating concept of the M Double Clutch Transmission used by other BMW M models. With its instantaneous responses, rapid gear changes and super-direct reaction to load changes, the torque converter auto links up seamlessly with the new higher-torque turbocharged engine and showcases its talents in hugely impressive style.

From the race track to the road.

In the development of every BMW M vehicle, a familiar maxim applies: it must be “fit for the Nordschleife-Nürburgring”. The aim in the development of BMW M cars is to master the world’s most challenging race track at race speed without any problems. The cooling systems for the all-new BMW X5 M and BMW X6 M are similarly track-ready. A combination of low-temperature

and high-temperature radiators ensures that the optimum temperature is maintained for cooling the engine water, charge air, engine oil and transmission oil – even when venturing into high-performance territory.

Chassis technology developed to M specification.

The all-new BMW X5 M and BMW X6 M are equipped with an extensive chassis technology, unbeatable directional stability and excellent traction, along with the type of neutral self-steering typical of M cars, in particular when accelerating out of corners and pushing their dynamic limits. Plus, Dynamic Damper Control with electronically adjustable dampers – the driver can select from three modes (COMFORT, SPORT and SPORT+) at the touch of a button – ensures the perfect balance between dynamic flair and driving comfort. Another central element in the driving characteristics of the all-new BMW X5 M and BMW X6 M are the special tyres, whose development closely followed that of the axle construction. In order to meet these part-contradictory, part-complementary demands, the BMW M engineers have developed two sets of mixed tyres for the all-new BMW X5 M and BMW X6 M.

Intelligent all-wheel drive.

BMW xDrive intelligent all-wheel drive and Dynamic Performance Control play a key role in the outstanding dynamics of the all-new BMW X5 M and new BMW X6 M. The xDrive system employs an electronically controlled multi-plate clutch to allow fully variable distribution of drive between the front and rear axles – from 100 percent at the rear to up to 100 percent at the front. This ensures the best possible traction in all road conditions. Working in combination with the xDrive all-wheel-drive system, the result is a whole new dimension of dynamic flair, agility and traction. The vehicle follows the course set by the driver far more accurately, whatever the road surface, and the system also reduces the amount of wheel work required of the driver: the steering responds more directly and far fewer corrections are necessary. The driver can see how Dynamic Performance Control is operating on the display, with arrows at all four wheels visualising where the engine power is currently being sent.

High-performance brakes borrowed from motor sport.

The remarkable dynamic potential of the BMW X5 M and BMW X6 M is backed up by the standard high-performance compound brakes with large six-piston fixed callipers at the front and single-piston floating callipers at the rear. All the brake discs are perforated and inner-

vented, and the brake callipers are painted in metallic Dark Blue, in typical M fashion, and marked at the front wheels with the M logo.

Sporting ambience and flawless ergonomics.

As with all vehicles from the BMW brand, the design of the interior prioritises intuitive, quick and error-free usability. BMW M also makes its own distinctive mark here. For example, the all-new BMW X5 M and BMW X6 M are fitted with a newly developed, ergonomically optimised M leather steering wheel with gearshift paddles, while the M gearshift lever has an equally distinctive design. The instrument cluster, M Drive menu in the information display, displays in the optional Head-Up Display and special multifunction switch with M Drive buttons on the steering wheel are also consistent with the M template.

The sporting ambience on board the new BMW X5 M and BMW X6 M is accentuated particularly strongly by the exclusive, electrically-operated M multifunction seats for the driver and front passenger – in fine-grain Merino leather with contrast stitching and embossed M logo in the backrests – and by the leather-covered BMW Individual instrument panel. Door sill strips with model lettering, aluminium interior trim strips and the anthracite-coloured BMW Individual roof liner as well as the Carbon fibre interior trim give the interior an additional touch of exclusivity. Customers can take the interior of their vehicles to an even higher level by specifying the optional full Merino leather trim including a roof liner in Alcantara. The all-new BMW X5 M is fitted as standard with polished 20-inch BMW M light-alloy wheels in Orbit Grey and with mixed tyres. The all-new BMW X6 M comes with polished, forged 21-inch BMW M light-alloy wheels in Orbit Grey with mixed tyres

High-quality standard equipment and exclusive options.

Also included in standard specifications for the all-new BMW X5 M and new BMW X6 M are automatic tailgate operation, automatically dimming rear-view and exterior mirrors, a headlight washer system, automatic 4-zone climate control, a harman/kardon surround sound speaker system and Park Distance Control with a rear-view camera. The vehicles also feature Adaptive LED Headlights with BMW Selective Beam, an anti-dazzle high-beam function, and the active cornering function.

Among the highlights of BMW ConnectedDrive is the new-generation Navigation system Professional, which boasts even greater capability and sharper graphics and incorporates 3D elements into its map display. The standard Head-Up Display for the BMW X5 M and BMW X6 M also features a special M display including a digital speed display, gear display, rev band and Shift Lights.

Add-ons for comprehensive driver information.

Keen track drivers will be pleased to hear that BMW M has developed a free BMW M Laptimer app, which allows owners to analyse their personal driving style. Once their smartphone is hooked up to the BMW – via USB cable or the car’s snap-in adapter – customers can operate the BMW M Laptimer app easily using the iDrive Touch Controller. The app then gets to work without delay, recording the car’s speed, longitudinal and lateral acceleration, engine revs, the gear engaged, steering angle, accelerator position and fuel consumption. This means that when the data is subsequently analysed via graphic displays on the customer’s smartphone, the driver’s reactions can also be assessed. Another feature allows two recordings on the same track to be compared corner-by-corner. The readings used here can be either the driver’s own or data shared via email.

Availability and Prices.

The all-new BMW X5 M and BMW X6 M will be available at BMW Authorized Dealers from June 2015. The all-new BMW X5 M will be offered at a price of Rp. 3,149,000,000 off-the-road, while the all-new BMW X6 M will be offered at a price of Rp. 3,249,000,000 off-the-road. Both vehicles come with BMW Service Inclusive, which includes free-of-charge regular maintenance for 5 years or 60,000 km, whichever comes first, as well as a 36-month warranty without mileage limitations.

###

1. The all-new BMW X5 M and BMW X6 M price list.
2. The all-new BMW X5 M and BMW X6 M specifications.
3. Exterior and interior dimensions.

The BMW Group

With its three brands BMW, MINI and Rolls-Royce, the BMW Group is the world’s leading premium manufacturer of automobiles and motorcycles and also provides premium financial and mobility services. As a global company, the BMW Group operates 30 production and assembly facilities in 14 countries and has a global sales network in more than 140 countries.

In 2014, the BMW Group sold approximately 2.118 million cars and 123,000 motorcycles worldwide. The profit before tax for the financial year 2013 was € 7.91 billion on revenues amounting to approximately €

76.06 billion. As of 31 December 2013, the BMW Group had a workforce of 110,351 employees.

The success of the BMW Group has always been based on long-term thinking and responsible action. The company has therefore established ecological and social sustainability throughout the value chain, comprehensive product responsibility and a clear commitment to conserving resources as an integral part of its strategy.

www.bmwgroup.com

Facebook: <http://www.facebook.com/BMWGroup>

Twitter: <http://twitter.com/BMWGroup>

YouTube: <http://www.youtube.com/BMWGroupview>

Google+: <http://googleplus.bmwgroup.com>

BMW Group Indonesia

BMW Group Indonesia is a wholly-owned subsidiary of Munich-based Bayerische Motoren Werke (BMW) AG in Germany. The establishment of this subsidiary in April 2001 reflects the BMW Group's confidence in the long-term future of Indonesia. BMW Indonesia Group activities cover the wholesale of BMW and MINI vehicles, spare parts and accessories, as well as the overall planning of sales, marketing, after-sales, and related activities in Indonesia. Its dealership network covers 18 new-car dealers and 5 BMW Premium Selection facilities spread out in various cities in Indonesia. Selected models of the BMW 3 Series, BMW 5 Series, BMW X1, BMW X3, and BMW X5 are assembled in Indonesia by a local partner.

www.bmw.co.id

Facebook: <http://www.facebook.com/BMW.Indonesia>

Twitter: http://twitter.com/BMW_Indonesia

YouTube: <http://www.youtube.com/BMWIndonesia>

For further information please contact:

Corporate Communications Department

Jodie O'tania

Tel: +62 -21- 2992 3000 ext 21732

Mobile: +62-8111534962

Email: jodie.otania@bmw.co.id

Alia Hadju

Tel: +62-21-2992 3000 ext 21724

Mobile: +62-812 853 222 53

Email: alia.hadju@bmw.co.id

1. The all-new BMW X5 M and BMW X6 M price list.

Model	Retail price (off-the road)
BMW X5 M	Rp. 3,149,000,000
BMW X6 M	Rp. 3,249,000,000

2. The all-new BMW X5 M and BMW X6 M specifications.

BMW X5 M and BMW X6 M	
4.4 liter V8 engine, BMW M TwinPower Turbo technology with variable inlet geometry, TwinScroll biturbo charging, High Precision Petrol Direct Injection, VALVETRONIC	
Capacity	4,395 cc
Max. output	575 hp at 6,000 and 6,500 rpm
Max. torque	750 Nm from 12,200 and 5,000 rpm.
Acceleration	0-100 km/h in 4.2 seconds
Top speed	250 km/h
Average fuel consumption (ECE-cycle):	9 km/liter
Combined CO ₂ emissions to the EU standard:	258 g/km, emissions standard: EU5

3. Exterior and interior dimension. The all-new BMW X5 M.

Ground clearance: 195 mm

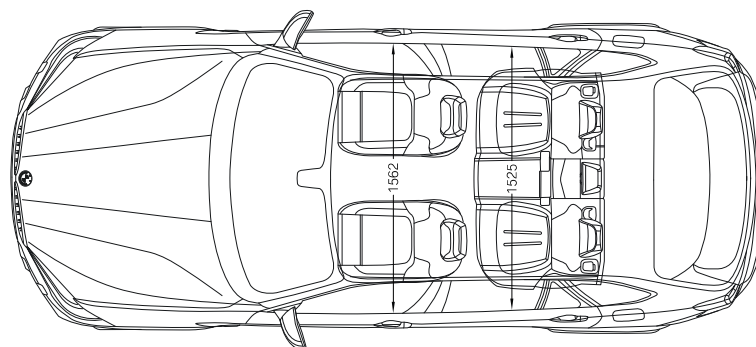
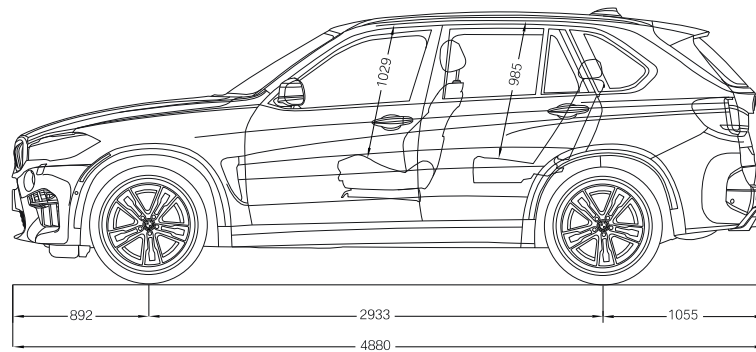
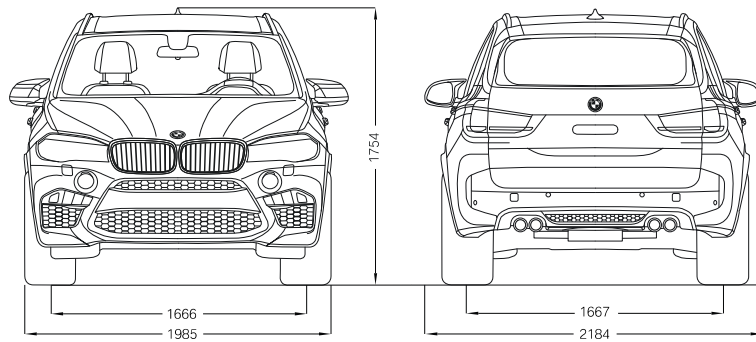

The all-new BMW X6 M.

Ground clearance: 195 mm

