

# Technical specifications.

## BMW X5.

### X5 xDrive50e.



BMW X5 xDrive50e		
<b>Body</b>		
No. of doors / seats		5 / 5
Length/width/height (unladen)	mm	4935 / 2004 / 1755
Wheelbase	mm	2975
Track, front/rear	mm	1677 / 1698
Turning circle	m	12.6
Fuel tank capacity	approx. l	69
Weight, unladen, to DIN/EU	kg	2420 / 2495
Max. load to DIN	kg	780
Max. permissible weight	kg	3200
Max. axle load, front/rear	kg	1400 / 1875
Max. trailer load braked (12%/unbraked)	kg	2700 / 750
Max. roofload/towbar download	kg	100 / 140
Luggage comp. capacity	l	500 – 1720
Air resistance	cx x A	0.33 x 2.93
<b>Power Unit</b>		
Drive concept		Full hybrid drive, drive torque from one or both sources (petrol engine/electric motor) sent to all four wheels via BMW xDrive
Max. system output <sup>1)</sup>	kW/hp	360 / 489
Max. system torque <sup>1)</sup>	Nm	700
System power-to-weight ratio (DIN)	kg/kW	6.7
<b>Petrol Engine</b>		
Config./No. of cyls./valves		In-line / 6 / 4
Engine technology		BMW TwinPower Turbo technology: turbocharger, High Precision Injection, VALVETRONIC fully variable valve timing, Double-VANOS variable camshaft timing
Effective capacity	cc	2998
Stroke/bore	mm	94.6 / 82.0
Compression ratio	:1	11.0
Fuel		Min. RON 91
Nominal power	kW/hp	230 / 313
at	rpm	5000 – 6500
Nominal torque	Nm	450
at	rpm	1750 – 4700
Output per litre	kW/l	76.7
<b>Electric Motor</b>		
Motor technology		BMW eDrive technology: synchronous electric motor with pre-gearing stage, integrated into eight-speed Steptronic transmission, generator function for recuperating energy for the high-voltage battery
Nominal power	kW/hp	145 / 197
at	rpm	7000
Nominal torque	Nm	280
at	rpm	100 – 5500
Effective torque resulting from pre-gearing	Nm	450
<b>High-voltage Battery</b>		
Storage technology / installation		Lithium-ion / underfloor
Voltage	V	238
Energy capacity (gross / net)	kWh	29.5 / 25.7
Charging time, 0–100% charge		4.5 h at 7.4 kW (32 A / 230 V, single-phase)
<b>Transmission</b>		
Type of transmission		Eight-speed Steptronic transmission
Gear ratios	I	:1 5.500
	II	:1 3.520
	III	:1 2.200
	IV	:1 1.720
	V	:1 1.301
	VI	:1 1.000
	VII	:1 0.833
	VIII	:1 0.640
	R	:1 4.543
Final drive		:1 3.636

**BMW X5 xDrive50e**

**Driving Dynamics and Safety**

Suspension, front	Double-wishbone axle in aluminium construction, adaptive suspension, air suspension with automatic self-levelling
Suspension, rear	Five-link axle in lightweight steel construction, adaptive suspension, air suspension with automatic self-levelling
Brakes, front	Four-piston fixed-calliper disc brakes
Brakes, rear	Single-piston floating-calliper disc brakes
Driving stability systems	Standard: DSC incl. ABS and DTC (Dynamic Traction Control), CBC (Cornering Brake Control), DBC (Dynamic Brake Control), Dry Braking function, fading compensation, drive-off assistant, DSC networked with xDrive all-wheel-drive system, ADB-X (Automatic Differential Brake), HDC (Hill Descent Control), trailer stability control
Safety equipment	Standard: airbags for driver and front passenger, side airbags for driver and front passenger, head airbags for front and rear seats, three-point inertia-reel seatbelts on all seats with belt stopper, belt tensioner and belt force limiter in the front, crash sensors, tyre pressure indicator
Steering	Electric Power Steering (EPS) with Servotronic function; optional: Integral Active Steering
Steering ratio, overall	:1 17.6
Tyres, front/rear	265/50 R19 110W XL
Rims, front/rear	9J x 19 light-alloy

**Performance**

Acceleration 0–100 km/h	s	4.8
Top speed	km/h	250
Top speed (electric)	km/h	140
Electric range (WLTP)	km	94 – 110

**Off-road Characteristics**

Angle of approach/departure	°	25.2 / 22.3
Breakover angle	°	20.2
Ground clearance (unladen)	mm	214
Fording depth (at 7 km/h)	mm	500

**BMW EfficientDynamics**

BMW EfficientDynamics standard features	BMW eDrive technology, adaptive Brake Energy Regeneration with recuperation display, Electric Power Steering, hybrid-specific Automatic Start Stop function, Optimum Shift Indicator, COMFORT and ECO PRO modes with coasting function, Proactive Driving Assistant, BMW EfficientLightweight, optimised aerodynamic attributes, active air flap control, on-demand operation of ancillary units, map-regulated oil pump, efficiency-optimised all-wheel drive, differential with optimised warm-up behaviour, tyres with reduced rolling resistance
---	--

**Fuel Consumption ECE**

Fuel consump. weighted comb. (WLTP)	l/100 km	1.1 – 0.8
Fuel consump weighted comb. (NEDC)	l/100 km	–
CO <sub>2</sub> emissions from fuel (WLTP)	g/km	26 – 18
CO <sub>2</sub> emissions from fuel (NEDC)	g/km	–
Elec. power cons. weighted comb.	kWh/100 km	27.0 – 22.9
Elec. power cons. weighted comb.	kWh/100 km	–
Emission rating		Euro 6d

Specifications apply to ACEA markets/data relevant to homologation applies in part only to Germany (weight)

<sup>1)</sup> Developed by the combination of the combustion engine (stated nominal figure) and the electric motor (up to stated nominal figure)

The fuel consumption, CO<sub>2</sub> emissions, electric power consumption and electric range figures are determined according to the European Regulation (EC) 715/2007 in the version applicable. The figures refer to a vehicle with basic configuration in Germany and the range shown considers the different sizes of the selected wheels/tyres and the selected items of optional equipment.

All values were calculated based on the new WLTP test cycle. WLTP values are taken as the basis for determining vehicle-related taxes or other duties based (at least inter alia) on CO<sub>2</sub> emissions as well as eligibility for any applicable vehicle-specific subsidies. Further information on the WLTP and NEDC measurement procedures can also be found at [www.bmw.de/wltp](http://www.bmw.de/wltp).

Further information on official fuel consumption figures and specific CO<sub>2</sub> emission values of new passenger cars is included in the following guideline: 'Leitfaden über den Kraftstoffverbrauch, die CO<sub>2</sub>-Emissionen und den Stromverbrauch neuer Personenkraftwagen' (Guide to the fuel economy, CO<sub>2</sub> emissions and electric power consumption of new passenger cars), which can be obtained free of charge from all dealerships, from Deutsche Automobil Treuhand GmbH (DAT), Hellmuth-Hirth-Str. 1, 73760 Ostfildern-Scharnhausen and at <https://www.dat.de/co2>.

# BMW X5. X5 xDrive40i.

BMW X5 xDrive40i		
<b>Body</b>		
No. of doors / seats		5 / 5 (7) <sup>1)</sup>
Length/width/height (unladen)	mm	4935 / 2004 / 1765
Wheelbase	mm	2975
Track, front/rear	mm	1677 / 1698
Turning circle	m	12.6
Fuel tank capacity	approx. l	83
Engine oil <sup>2)</sup>	l	<sup>4)</sup>
Weight, unladen, to DIN/EU	kg	2165 / 2240
Max. load to DIN	kg	720
Max. permissible weight	kg	2885
Max. axle load, front/rear	kg	1350 / 1680
Max. trailer load		
braked (12%)/unbraked	kg	3500 / 750
Max. roofload/towbar download	kg	100 / 140
Luggage comp. capacity	l	650 – 1870
Air resistance	cx x A	0.33 x 2.93
<b>Power Unit</b>		
Engine technology		BMW TwinPower Turbo technology: turbocharger, High Precision Injection, VALVETRONIC fully variable valve timing, Double-VANOS variable camshaft timing, 48V mild hybrid technology using an electric motor integrated into the transmission
Max. output, overall <sup>3)</sup>	kW/hp	280 / 381
Max. torque, overall <sup>3)</sup>	Nm	540
<b>Petrol Engine</b>		
Config./No. of cyls./valves		In-line / 6 / 4
Effective capacity	cc	2998
Stroke/bore	mm	94.6 / 82.0
Compression ratio	:1	11.0
Fuel		Min. RON 91
Nominal power	kW/hp	280 / 381
at	rpm	5200 – 6250
Nominal torque	Nm	520
at	rpm	1850 – 5000
Output per litre	kW/l	93.4
<b>Electric Motor</b>		
Nominal power	kW/hp	9 / 12
Nominal torque	Nm	200
<b>Electrical System</b>		
12V battery/installation	Ah/–	90 / luggage compartment
48V battery/installation	Ah/–	20 / engine compartment
<b>Driving Dynamics and Safety</b>		
Suspension, front		Double-wishbone axle in aluminium construction, adaptive suspension; optional: adaptive M suspension, air suspension with automatic self-levelling
Suspension, rear		Five-link axle in lightweight steel construction, adaptive suspension; optional: adaptive M suspension, air suspension with automatic self-levelling
Brakes, front		Four-piston fixed-calliper disc brakes
Brakes, rear		Single-piston floating-calliper disc brakes
Driving stability systems		Standard: DSC incl. ABS and DTC (Dynamic Traction Control), CBC (Cornering Brake Control), DBC (Dynamic Brake Control), Dry Braking function, fading compensation, drive-off assistant, DSC networked with xDrive all-wheel-drive system, ADB-X (Automatic Differential Brake), HDC (Hill Descent Control), trailer stability control; optional: active roll stabilisation, M Sport differential
Safety equipment		Standard: airbags for driver and front passenger, side airbags for driver and front passenger, head airbags for front and rear seats, three-point inertia-reel seatbelts on all seats with belt tensioner and belt force limiter in the front, crash sensors, tyre pressure indicator
Steering		Electric Power Steering (EPS) with Servotronic function; optional: Integral Active Steering
Steering ratio, overall	:1	17.6
Tyres, front/rear		265/50 R19 110W XL
Rims, front/rear		9J x 19 light-alloy

<b>BMW X5 xDrive40i</b>			
<b>Transmission</b>			
Type of transmission	Eight-speed Steptronic transmission		
Gear ratios	I	:1	5.250
	II	:1	3.360
	III	:1	2.172
	IV	:1	1.720
	V	:1	1.316
	VI	:1	1.000
	VII	:1	0.822
	VIII	:1	0.640
	R	:1	3.712
Final drive		:1	3.385
<b>Performance</b>			
Power-to-weight ratio (DIN)	kg/kW		7.7
Acceleration 0–100 km/h	s		5.4
Top speed	km/h		250
<b>Off-road Characteristics</b>			
Angle of approach/departure	°		25.2 / 22.3
Breakover angle	°		20.2
Ground clearance (unladen)	mm		214
Fording depth (at 7 km/h)	mm		500
<b>BMW EfficientDynamics</b>			
BMW EfficientDynamics standard features	48V mild hybrid technology, Brake Energy Regeneration with recuperation display, Automatic Start/Stop function, COMFORT and ECO PRO modes with coasting function, Proactive Driving Assistant, Optimum Shift Indicator, Electric Power Steering, BMW EfficientLightweight, optimised aerodynamic attributes, active air flap control, on-demand operation of ancillary units, map-regulated oil pump, efficiency-optimised all-wheel drive, differential with optimised warm-up behaviour, tyres with reduced rolling resistance		
<b>Fuel Consumption ECE</b>			
Combined (WLTP)	l/100		9.9 – 8.5
Combined (NEDC)	l/100		–
CO <sub>2</sub> (WLTP)	g/km		224 – 193
CO <sub>2</sub> (NEDC)	g/km		–
Emission rating			Euro 6d

Specifications apply to ACEA markets/data relevant to homologation applies in part only to Germany (weight)

<sup>1)</sup> With optional third row of seats

<sup>2)</sup> Oil change

<sup>3)</sup> Developed by the combination of the combustion engine (stated nominal figure) and the electric motor (up to stated nominal figure)

<sup>4)</sup> Data not yet available

The fuel consumption, CO<sub>2</sub> emissions, electric power consumption and electric range figures are determined according to the European Regulation (EC) 715/2007 in the version applicable. The figures refer to a vehicle with basic configuration in Germany and the range shown considers the different sizes of the selected wheels/tyres and the selected items of optional equipment.

All values were calculated based on the new WLTP test cycle. WLTP values are taken as the basis for determining vehicle-related taxes or other duties based (at least inter alia) on CO<sub>2</sub> emissions as well as eligibility for any applicable vehicle-specific subsidies. Further information on the WLTP and NEDC measurement procedures can also be found at [www.bmw.de/wltp](http://www.bmw.de/wltp).

Further information on official fuel consumption figures and specific CO<sub>2</sub> emission values of new passenger cars is included in the following guideline: 'Leitfaden über den Kraftstoffverbrauch, die CO<sub>2</sub>-Emissionen und den Stromverbrauch neuer Personenkraftwagen' (Guide to the fuel economy, CO<sub>2</sub> emissions and electric power consumption of new passenger cars), which can be obtained free of charge from all dealerships, from Deutsche Automobil Treuhand GmbH (DAT), Hellmuth-Hirth-Str. 1, 73760 Ostfildern-Scharnhausen and at <https://www.dat.de/co2>.

# BMW X5. X5 M60i xDrive.

BMW X5 M60i xDrive		
<b>Body</b>		
No. of doors / seats		5 / 5
Length/width/height (unladen)	mm	4935 / 2004 / 1765
Wheelbase	mm	2975
Track, front/rear	mm	1679 / 1688
Turning circle	m	12.0
Fuel tank capacity	approx. l	83
Engine oil <sup>1)</sup>	l	<sup>3)</sup>
Weight, unladen, to DIN/EU	kg	2345 / 2420
Max. load to DIN	kg	720
Max. permissible weight	kg	3065
Max. axle load, front/rear	kg	1430 / 1680
Max. trailer load		
braked (12%/unbraked)	kg	3500 / 750
Max. roofload/towbar download	kg	100 / 140
Luggage comp. capacity	l	650 – 1870
Air resistance	cx x A	0.36 x 2.93
<b>Power Unit</b>		
Engine technology		M TwinPower Turbo technology with cross-bank exhaust manifold: two twin-scroll turbochargers, High Precision Injection, VALVETRONIC fully variable valve timing, Double-VANOS variable camshaft timing, 48V mild hybrid technology using an electric motor integrated into the transmission
Max. output, overall <sup>2)</sup>	kW/hp	390 / 530
Max. torque, overall <sup>2)</sup>	Nm	750
<b>Petrol Engine</b>		
Config./No. of cyls./valves		V / 8 / 4
Effective capacity	cc	4395
Stroke/bore	mm	88.3 / 89.0
Compression ratio	:1	10.5
Fuel		Min. RON 91
Nominal power	kW/hp	390 / 530
at	rpm	5500 – 6000
Nominal torque	Nm	750
at	rpm	1800 – 4600
Output per litre	kW/l	88.7
<b>Electric Motor</b>		
Nominal power	kW/hp	9 / 12
Nominal torque	Nm	200
<b>Electrical System</b>		
12V battery/installation	Ah/–	90 / luggage compartment
48V battery/installation	Ah/–	20 / engine compartment
<b>Driving Dynamics and Safety</b>		
Suspension, front		Double-wishbone axle in aluminium construction, adaptive M suspension; optional: air suspension with automatic self-levelling
Suspension, rear		Five-link axle in lightweight steel construction, adaptive M suspension; optional: air suspension with automatic self-levelling
Brakes, front		Four-piston fixed-calliper disc brakes
Brakes, rear		Single-piston floating-calliper disc brakes
Driving stability systems		Standard: DSC incl. ABS and DTC (Dynamic Traction Control), CBC (Cornering Brake Control), DBC (Dynamic Brake Control), Dry Braking function, fading compensation, drive-off assistant, DSC networked with xDrive all-wheel-drive system, ADB-X (Automatic Differential Brake), HDC (Hill Descent Control), trailer stability control, M Sport differential; optional: active roll stabilisation
Safety equipment		Standard: airbags for driver and front passenger, side airbags for driver and front passenger, head airbags for front and rear seats, three-point inertia-reel seatbelts on all seats with belt tensioner and belt force limiter in the front, crash sensors, tyre pressure indicator
Steering		Electric Power Steering (EPS) with Servotronic function, Integral Active Steering
Steering ratio, overall	:1	17.6
Tyres, front/rear		275/40 R21 107Y XL / 315/35 R21 111Y XL
Rims, front/rear		9.5J x 21 light-alloy / 10.5J x 21 light-alloy

<b>BMW X5 M60i xDrive</b>			
<b>Transmission</b>			
Type of transmission	Eight-speed Steptronic transmission		
Gear ratios	I	:1	5.501
	II	:1	3.520
	III	:1	2.200
	IV	:1	1.720
	V	:1	1.301
	VI	:1	1.000
	VII	:1	0.833
	VIII	:1	0.640
	R	:1	4.543
Final drive		:1	3.154
<b>Performance</b>			
Power-to-weight ratio (DIN)	kg/kW		6.0
Acceleration 0–100 km/h	s		4.3
Top speed	km/h		250
<b>Off-road Characteristics</b>			
Angle of approach/departure	°		25.2 / 22.3
Breakover angle	°		20.2
Ground clearance (unladen)	mm		214
Fording depth (at 7 km/h)	mm		500
<b>BMW EfficientDynamics</b>			
BMW EfficientDynamics standard features	48V mild hybrid technology, Brake Energy Regeneration with recuperation display, Automatic Start/Stop function, COMFORT and ECO PRO modes with coasting function, Proactive Driving Assistant, Optimum Shift Indicator, Electric Power Steering, BMW EfficientLightweight, optimised aerodynamic attributes, active air flap control, on-demand operation of ancillary units, map-regulated oil pump, efficiency-optimised all-wheel drive, differential with optimised warm-up behaviour, tyres with reduced rolling resistance		
<b>Fuel Consumption ECE</b>			
Combined (WLTP)	l/100		12.5 – 11.5
Combined (NEDC)	l/100		–
CO <sub>2</sub> (WLTP)	g/km		283 – 261
CO <sub>2</sub> (NEDC)	g/km		–
Emission rating			Euro 6d

Specifications apply to ACEA markets/data relevant to homologation applies in part only to Germany (weight)

<sup>1)</sup> Oil change

<sup>2)</sup> Developed by the combination of the combustion engine (stated nominal figure) and the electric motor (up to stated nominal figure)

<sup>3)</sup> Data not yet available

The fuel consumption, CO<sub>2</sub> emissions, electric power consumption and electric range figures are determined according to the European Regulation (EC) 715/2007 in the version applicable. The figures refer to a vehicle with basic configuration in Germany and the range shown considers the different sizes of the selected wheels/tyres and the selected items of optional equipment.

All values were calculated based on the new WLTP test cycle. WLTP values are taken as the basis for determining vehicle-related taxes or other duties based (at least inter alia) on CO<sub>2</sub> emissions as well as eligibility for any applicable vehicle-specific subsidies. Further information on the WLTP and NEDC measurement procedures can also be found at [www.bmw.de/wltp](http://www.bmw.de/wltp).

Further information on official fuel consumption figures and specific CO<sub>2</sub> emission values of new passenger cars is included in the following guideline: 'Leitfaden über den Kraftstoffverbrauch, die CO<sub>2</sub>-Emissionen und den Stromverbrauch neuer Personenkraftwagen' (Guide to the fuel economy, CO<sub>2</sub> emissions and electric power consumption of new passenger cars), which can be obtained free of charge from all dealerships, from Deutsche Automobil Treuhand GmbH (DAT), Hellmuth-Hirth-Str. 1, 73760 Ostfildern-Scharnhausen and at <https://www.dat.de/co2>.

# BMW X5. X5 xDrive30d.

BMW X5 xDrive30d		
<b>Body</b>		
No. of doors / seats		5 / 5 (7) <sup>1)</sup>
Length/width/height (unladen)	mm	4935 / 2004 / 1765
Wheelbase	mm	2975
Track, front/rear	mm	1677 / 1698
Turning circle	m	12.6
Fuel tank capacity	approx. l	80
Engine oil <sup>2)</sup>	l	<sup>4)</sup>
Weight, unladen, to DIN/EU	kg	2220 / 2295
Max. load to DIN	kg	730
Max. permissible weight	kg	2950
Max. axle load, front/rear	kg	1360 / 1680
Max. trailer load braked (12%/unbraked)	kg	3500 / 750
Max. roofload/towbar download	kg	100 / 140
Luggage comp. capacity	l	650 – 1870
Air resistance	cx x A	0.33 x 2.93
<b>Power Unit</b>		
Engine technology		BMW TwinPower Turbo technology: multi-stage turbocharging, low-pressure turbocharger with variable inlet geometry, common-rail direct injection with solenoid injectors (max. injection pressure: 2500 bar), 48V mild hybrid technology using an electric motor integrated into the transmission
Max. output, overall <sup>3)</sup>	kW/hp	219 / 298
Max. torque, overall <sup>3)</sup>	Nm	670
<b>Diesel Engine</b>		
Config./No. of cyls./valves		In-line / 6 / 4
Effective capacity	cc	2993
Stroke/bore	mm	90.0 / 84.0
Compression ratio	:1	16.5
Fuel		Diesel
Nominal power	kW/hp	210 / 286
at	rpm	4000
Nominal torque	Nm	650
at	rpm	1500 – 2500
Output per litre	kW/l	70.2
<b>Electric Motor</b>		
Nominal power	kW/hp	9 / 12
Nominal torque	Nm	200
<b>Electrical System</b>		
12V battery/installation	Ah/-	90 / luggage compartment
48V battery/installation	Ah/-	20 / engine compartment
<b>Driving Dynamics and Safety</b>		
Suspension, front		Double-wishbone axle in aluminium construction, adaptive suspension; optional: adaptive M suspension, air suspension with automatic self-levelling
Suspension, rear		Five-link axle in lightweight steel construction, adaptive suspension; optional: adaptive M suspension, air suspension with automatic self-levelling
Brakes, front		Four-piston fixed-calliper disc brakes
Brakes, rear		Single-piston floating-calliper disc brakes
Driving stability systems		Standard: DSC incl. ABS and DTC (Dynamic Traction Control), CBC (Cornering Brake Control), DBC (Dynamic Brake Control), Dry Braking function, fading compensation, drive-off assistant, DSC networked with xDrive all-wheel-drive system, ADB-X (Automatic Differential Brake), HDC (Hill Descent Control), trailer stability control; optional: active roll stabilisation, M Sport differential
Safety equipment		Standard: airbags for driver and front passenger, side airbags for driver and front passenger, head airbags for front and rear seats, three-point inertia-reel seatbelts on all seats with belt tensioner and belt force limiter in the front, crash sensors, tyre pressure indicator
Steering		Electric Power Steering (EPS) with Servotronic function; optional: Integral Active Steering
Steering ratio, overall	:1	17.6
Tyres, front/rear		265/50 R19 110W XL
Rims, front/rear		9J x 19 light-alloy

<b>BMW X5 xDrive30d</b>			
<b>Transmission</b>			
Type of transmission	Eight-speed Steptronic transmission		
Gear ratios	I	:1	5.501
	II	:1	3.520
	III	:1	2.200
	IV	:1	1.720
	V	:1	1.301
	VI	:1	1.000
	VII	:1	0.833
	VIII	:1	0.640
	R	:1	4.543
Final drive		:1	2.929
<b>Performance</b>			
Power-to-weight ratio (DIN)	kg/kW		10.1
Acceleration 0–100 km/h	s		6.1
Top speed	km/h		233
<b>Off-road Characteristics</b>			
Angle of approach/departure	°		25.2 / 22.3
Breakover angle	°		20.2
Ground clearance (unladen)	mm		214
Fording depth (at 7 km/h)	mm		500
<b>BMW EfficientDynamics</b>			
BMW EfficientDynamics standard features	48V mild hybrid technology, Brake Energy Regeneration with recuperation display, Automatic Start/Stop function, COMFORT and ECO PRO modes with coasting function, Proactive Driving Assistant, Optimum Shift Indicator, Electric Power Steering, BMW EfficientLightweight, optimised aerodynamic attributes, active air flap control, on-demand operation of ancillary units, map-regulated oil pump, efficiency-optimised all-wheel drive, differential with optimised warm-up behaviour, tyres with reduced rolling resistance, BMW Blue Performance technology with SCR catalytic converter		
<b>Fuel Consumption ECE</b>			
Combined (WLTP)	l/100		8.2 – 7.1
Combined (NEDC)	l/100		–
CO <sub>2</sub> (WLTP)	g/km		215 – 186
CO <sub>2</sub> (NEDC)	g/km		–
Emission rating			Euro 6d

Specifications apply to ACEA markets/data relevant to homologation applies in part only to Germany (weight)

<sup>1)</sup> With optional third row of seats

<sup>2)</sup> Oil change

<sup>3)</sup> Developed by the combination of the combustion engine (stated nominal figure) and the electric motor (up to stated nominal figure)

<sup>4)</sup> Data not yet available

The fuel consumption, CO<sub>2</sub> emissions, electric power consumption and electric range figures are determined according to the European Regulation (EC) 715/2007 in the version applicable. The figures refer to a vehicle with basic configuration in Germany and the range shown considers the different sizes of the selected wheels/tyres and the selected items of optional equipment.

All values were calculated based on the new WLTP test cycle. WLTP values are taken as the basis for determining vehicle-related taxes or other duties based (at least inter alia) on CO<sub>2</sub> emissions as well as eligibility for any applicable vehicle-specific subsidies. Further information on the WLTP and NEDC measurement procedures can also be found at [www.bmw.de/wltp](http://www.bmw.de/wltp).

Further information on official fuel consumption figures and specific CO<sub>2</sub> emission values of new passenger cars is included in the following guideline: 'Leitfaden über den Kraftstoffverbrauch, die CO<sub>2</sub>-Emissionen und den Stromverbrauch neuer Personenkraftwagen' (Guide to the fuel economy, CO<sub>2</sub> emissions and electric power consumption of new passenger cars), which can be obtained free of charge from all dealerships, from Deutsche Automobil Treuhand GmbH (DAT), Hellmuth-Hirth-Str. 1, 73760 Ostfildern-Scharnhausen and at <https://www.dat.de/co2>.



# Exterior and interior dimensions. BMW X5.

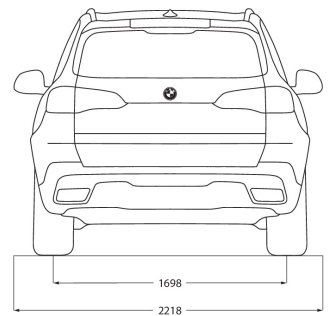
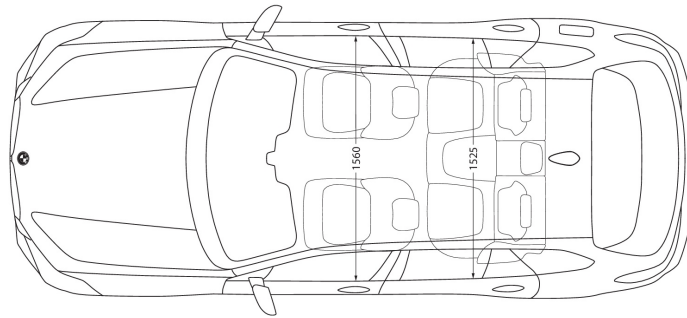
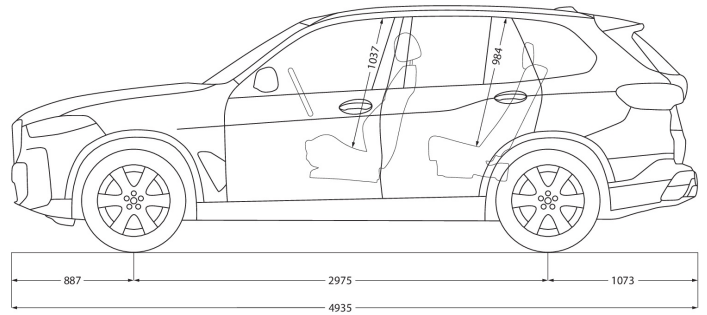
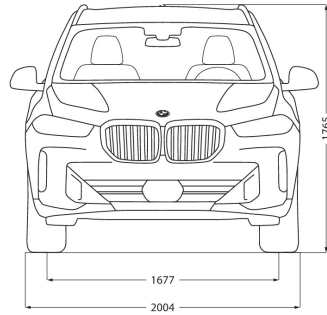

The dimensions indicated in the technical drawing are in millimetres and may vary depending on the model and the items of optional equipment fitted.