

# Specifications.

## The new BMW X5 M. X5 M.



<b>BMW X5 M</b>		
<b>Body</b>		
No of doors/seats		5 / 5
Length/width/height (unladen)	mm	4938 / 2015 / 1747
Wheelbase	mm	2972
Track, front/rear	mm	1699 / 1688
Ground clearance	mm	212
Turning circle	m	12.8
Fuel tank capacity	approx. l	83
Engine oil <sup>1)</sup>	l	10.0
Weight, unladen, to DIN/EU	kg	2310 / 2385
Max load to DIN	kg	690
Max permissible weight	kg	3000
Max axle load, front/rear	kg	1410 / 1630
Max trailer load, braked (12%/unbraked)	kg	3000 / 750
Max roofload/max towbar download	kg	100 / 140
Luggage comp capacity	l	650 – 1870
Air resistance	$c_d \times A$	0.38 x 2.99
<b>Power Unit</b>		
Config/No of cyls/valves		V / 8 / 4
Engine technology		M TwinPower Turbo technology with cross-bank exhaust manifold: M TwinScroll twin turbocharger, indirect charge air cooling, High Precision Injection (maximum injection pressure: 350 bar), VALVETRONIC fully variable valve timing, Double-VANOS variable camshaft timing
Effective capacity	cc	4395
Stroke/bore	mm	88.3 / 89.0
Compression ratio	:1	10.0
Fuel		RON 98 (min. RON 91)
Max output	kW/hp	441 / 600
at	rpm	6000
Max torque	Nm	750
at	rpm	1800 – 5600
<b>Electrical System</b>		
Battery/installation	Ah-	105 / luggage compartment
<b>Driving Dynamics and Safety</b>		
Suspension, front		Adaptive M suspension with double wishbone axle in lightweight aluminium construction, M-specific kinematics and elastokinematics, Variable Damper Control
Suspension, rear		Adaptive M suspension with five-link axle in lightweight aluminium construction, M-specific elastokinematics, Variable Damper Control
Brakes, front		M compound brakes, vented, with six-piston fixed callipers
Brakes, rear		M compound brakes, vented, with single-piston floating callipers
Driving stability systems		Standard: DSC incl. ABS, ASC and M Dynamic Mode (MDM), can be switched off; CBC (Cornering Brake Control), DBC (Dynamic Brake Control), Dry Braking function, Start-Off Assistant, Active M Differential, DSC linked with M xDrive all-wheel drive
Safety equipment		Standard: airbags for driver and front passenger, side airbags for driver and front passenger, head airbags for front and rear seats, three-point inertia-reel seatbelts on all seats with belt stopper, belt latch tensioner and belt force limiter in the front, crash-active front head restraints, crash sensors, tyre pressure indicator
Steering		Electric Power Steering (EPS) with M-specific Servotronic function and variable sport ratio
Steering ratio, overall	:1	13.0
Tyres, front/rear		295/35 ZR21 107Y XL 315/35 ZR21 111Y XL
Rims, front/rear		10.5J x 21 light-alloy 11.5J x 21 light-alloy

**BMW X5 M**

**Power Transfer**

M xDrive intelligent all-wheel drive, central transfer case with fully-variable multi-plate clutch, fully-variable torque distribution between front and rear axle, rear differential with fully-variable Active M Differential, locking effect 0 – 100 per cent

**Transmission**

Type of transmission	Eight-speed M Steptronic transmission with Drivelogic, transmission oil cooling		
Gear ratios	I	:1	5.000
	II	:1	3.200
	III	:1	2.143
	IV	:1	1.720
	V	:1	1.313
	VI	:1	1.000
	VII	:1	0.823
	VIII	:1	0.640
	R	:1	3.478
Final drive		:1	3.154

**Performance**

Power-to-weight ratio (DIN)	kg/kW	5.2
Output per litre	kW/l	100.3
Acceleration 0–100 km/h	s	3.9
Acceleration 0–200 km/h	s	13.5
Top speed	km/h	250 / 290 <sup>2)</sup>

**BMW EfficientDynamics**

BMW EfficientDynamics standard features Brake Energy Regeneration, Electric Power Steering, Auto Start Stop function, Optimum Shift Indicator in manual shift mode, BMW EfficientLightweight, on-demand operation of ancillary units, Li-ion battery, map-regulated oil pump, rear differential and transfer case with optimised efficiency, optimised aerodynamics (underside panelling, front spoiler, roof spoiler)

**Fuel Consumption ECE**

with standard tyres		
Urban	l/100 km	17.2 – 16.5
Extra-urban	l/100 km	11.0 – 10.5
Combined	l/100 km	13.0 – 12.8
CO <sub>2</sub>	g/km	296 – 291
Emission rating		Euro 6d-TEMP

Specifications apply to ACEA markets/data relevant to homologation applies in part only to Germany (weight)

<sup>1)</sup> Oil change with filter

<sup>2)</sup> Limited / with optional M Driver's Package

The fuel consumption, CO<sub>2</sub> emission and electric power consumption figures are determined according to the European Regulation (EC) 715/2007 in the version applicable. The figures refer to a vehicle with basic configuration in Germany. The range shown considers the different sizes of the selected wheels/tyres and the selected items of optional equipment, and may vary during configuration.

The values are based on the new WLTP test cycle and are translated back into NEDC-equivalent values in order to ensure comparability between the vehicles. With respect to these vehicles, for vehicle-related taxes or other duties based (at least inter alia) on CO<sub>2</sub> emissions, the CO<sub>2</sub> values may differ from the values stated here (depending on national legislation).

Further information on official fuel consumption figures and specific CO<sub>2</sub> emission values of new passenger cars is included in the following guideline: 'Leitfaden über den Kraftstoffverbrauch, die CO<sub>2</sub>-Emissionen und den Stromverbrauch neuer Personenkraftwagen' (Guide to the fuel economy, CO<sub>2</sub> emissions and electric power consumption of new passenger cars), which can be obtained free of charge from all dealerships, from Deutsche Automobil Treuhand GmbH (DAT), Hellmuth-Hirth-Str. 1, 73760 Ostfildern-Scharnhausen and at <https://www.dat.de/co2/>.

# The new BMW X5 M. X5 M Competition.

<b>BMW X5 M Competition</b>		
<b>Body</b>		
No of doors/seats		5 / 5
Length/width/height (unladen)	mm	4938 / 2015 / 1748
Wheelbase	mm	2972
Track, front/rear	mm	1699 / 1688
Ground clearance	mm	212
Turning circle	m	12.8
Fuel tank capacity	approx. l	83
Engine oil <sup>1)</sup>	l	10.0
Weight, unladen, to DIN/EU	kg	2310 / 2385
Max load to DIN	kg	690
Max permissible weight	kg	3000
Max axle load, front/rear	kg	1410 / 1630
Max trailer load, braked (12%/unbraked)	kg	3000 / 750
Max roofload/max towbar download	kg	100 / 140
Luggage comp capacity	l	650 – 1870
Air resistance	$c_d \times A$	0.38 x 2.99
<b>Power Unit</b>		
Config/No of cyls/valves		V / 8 / 4
Engine technology		M TwinPower Turbo technology with cross-bank exhaust manifold: M TwinScroll twin turbocharger, indirect charge air cooling, High Precision Injection (maximum injection pressure: 350 bar), VALVETRONIC fully variable valve timing, Double-VANOS variable camshaft timing
Effective capacity	cc	4395
Stroke/bore	mm	88.3 / 89.0
Compression ratio	:1	10.0
Fuel		RON 98 (min. RON 91)
Max output	kW/hp	460 / 625
at	rpm	6000
Max torque	Nm	750
at	rpm	1800 – 5800
<b>Electrical System</b>		
Battery/installation	Ah/-	105 / luggage compartment
<b>Driving Dynamics and Safety</b>		
Suspension, front		Adaptive M suspension with double wishbone axle in lightweight aluminium construction, M-specific kinematics and elastokinematics, Variable Damper Control
Suspension, rear		Adaptive M suspension with five-link axle in lightweight aluminium construction, M-specific elastokinematics, Variable Damper Control
Brakes, front		M compound brakes, vented, with six-piston fixed callipers
Brakes, rear		M compound brakes, vented, with single-piston floating callipers
Driving stability systems		Standard: DSC incl. ABS, ASC and M Dynamic Mode (MDM), can be switched off; CBC (Cornering Brake Control), DBC (Dynamic Brake Control), Dry Braking function, Start-Off Assistant, Active M Differential, DSC linked with M xDrive all-wheel drive
Safety equipment		Standard: airbags for driver and front passenger, side airbags for driver and front passenger, head airbags for front and rear seats, three-point inertia-reel seatbelts on all seats with belt stopper, belt latch tensioner and belt force limiter in the front, crash-active front head restraints, crash sensors, tyre pressure indicator
Steering		Electric Power Steering (EPS) with M-specific Servotronic function and variable sport ratio
Steering ratio, overall	:1	13.0
Tyres, front/rear		295/35 ZR21 107Y XL 315/30 ZR22 107Y XL
Rims, front/rear		10.5J x 21 light-alloy 11.5J x 22 light-alloy

**BMW X5 M Competition**

**Power Transfer**

M xDrive intelligent all-wheel drive, central transfer case with fully-variable multi-plate clutch, fully-variable torque distribution between front and rear axle, rear differential with fully-variable Active M Differential, locking effect 0 – 100 per cent

**Transmission**

Type of transmission	Eight-speed M Steptronic transmission with Drivelogic, transmission oil cooling		
Gear ratios	I	:1	5.000
	II	:1	3.200
	III	:1	2.143
	IV	:1	1.720
	V	:1	1.313
	VI	:1	1.000
	VII	:1	0.823
	VIII	:1	0.640
	R	:1	3.478
Final drive		:1	3.154

**Performance**

Power-to-weight ratio (DIN)	kg/kW	5.0
Output per litre	kW/l	104.7
Acceleration 0–100 km/h	s	3.8
Acceleration 0–200 km/h	s	13.4
Top speed	km/h	250 / 290 <sup>2)</sup>

**BMW EfficientDynamics**

BMW EfficientDynamics standard features Brake Energy Regeneration, Electric Power Steering, Auto Start Stop function, Optimum Shift Indicator in manual shift mode, BMW EfficientLightweight, on-demand operation of ancillary units, Li-ion battery, map-regulated oil pump, rear differential and transfer case with optimised efficiency, optimised aerodynamics (underside panelling, front spoiler, roof spoiler)

**Fuel Consumption ECE**

with standard tyres		
Urban	l/100 km	17.2 – 16.5
Extra-urban	l/100 km	11.0 – 10.5
Combined	l/100 km	13.0 – 12.8
CO <sub>2</sub>	g/km	296 – 291
Emission rating		Euro 6d-TEMP

Specifications apply to ACEA markets/data relevant to homologation applies in part only to Germany (weight)

<sup>1)</sup> Oil change with filter

<sup>2)</sup> Limited / with optional M Driver's Package

The fuel consumption, CO<sub>2</sub> emission and electric power consumption figures are determined according to the European Regulation (EC) 715/2007 in the version applicable. The figures refer to a vehicle with basic configuration in Germany. The range shown considers the different sizes of the selected wheels/tyres and the selected items of optional equipment, and may vary during configuration.

The values are based on the new WLTP test cycle and are translated back into NEDC-equivalent values in order to ensure comparability between the vehicles. With respect to these vehicles, for vehicle-related taxes or other duties based (at least inter alia) on CO<sub>2</sub> emissions, the CO<sub>2</sub> values may differ from the values stated here (depending on national legislation).

Further information on official fuel consumption figures and specific CO<sub>2</sub> emission values of new passenger cars is included in the following guideline: 'Leitfaden über den Kraftstoffverbrauch, die CO<sub>2</sub>-Emissionen und den Stromverbrauch neuer Personenkraftwagen' (Guide to the fuel economy, CO<sub>2</sub> emissions and electric power consumption of new passenger cars), which can be obtained free of charge from all dealerships, from Deutsche Automobil Treuhand GmbH (DAT), Hellmuth-Hirth-Str. 1, 73760 Ostfildern-Scharnhausen and at <https://www.dat.de/co2/>.

# Output and torque diagrams. The new BMW X5 M. X5 M.

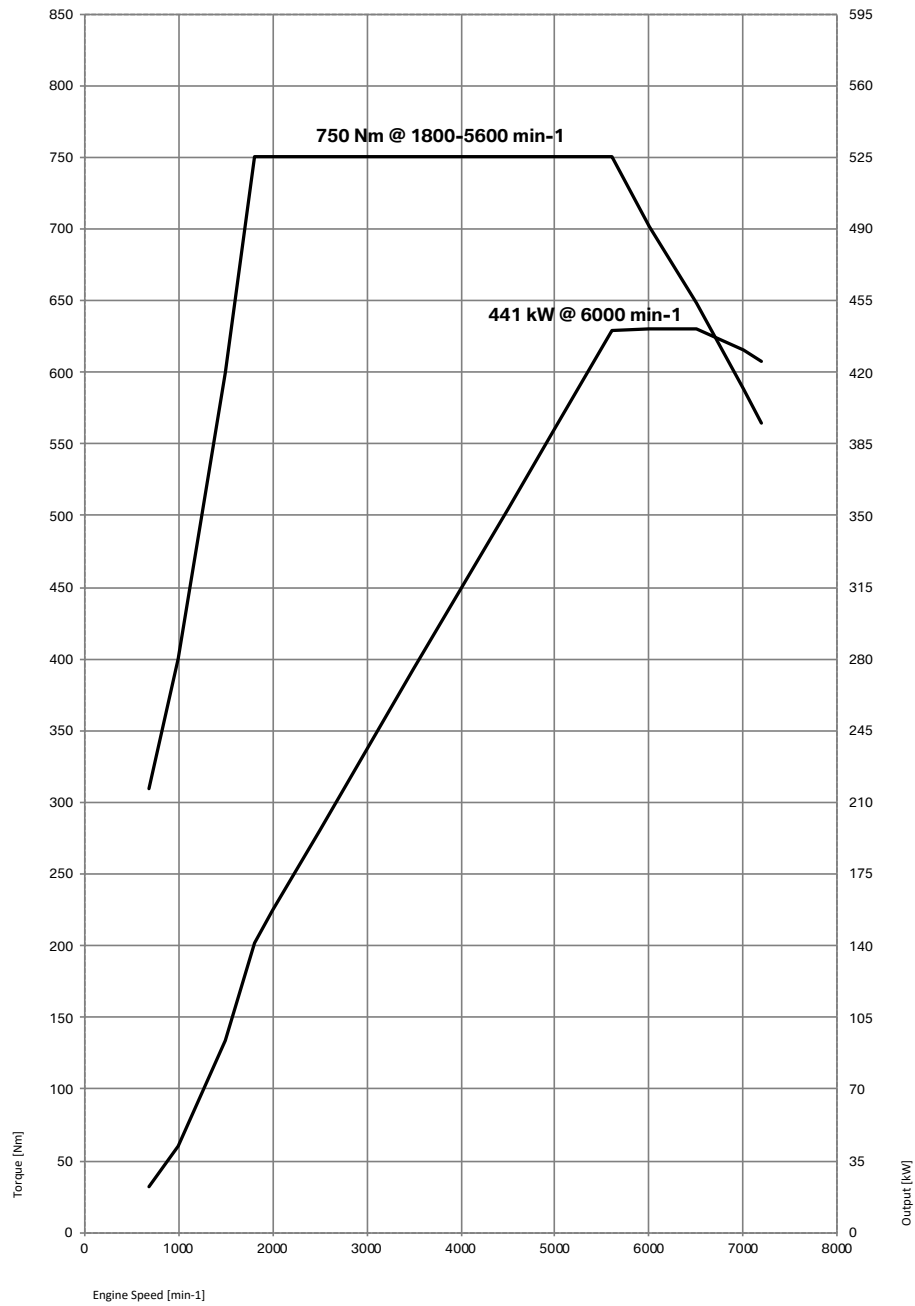

# The new BMW X5 M. X5 M Competition.

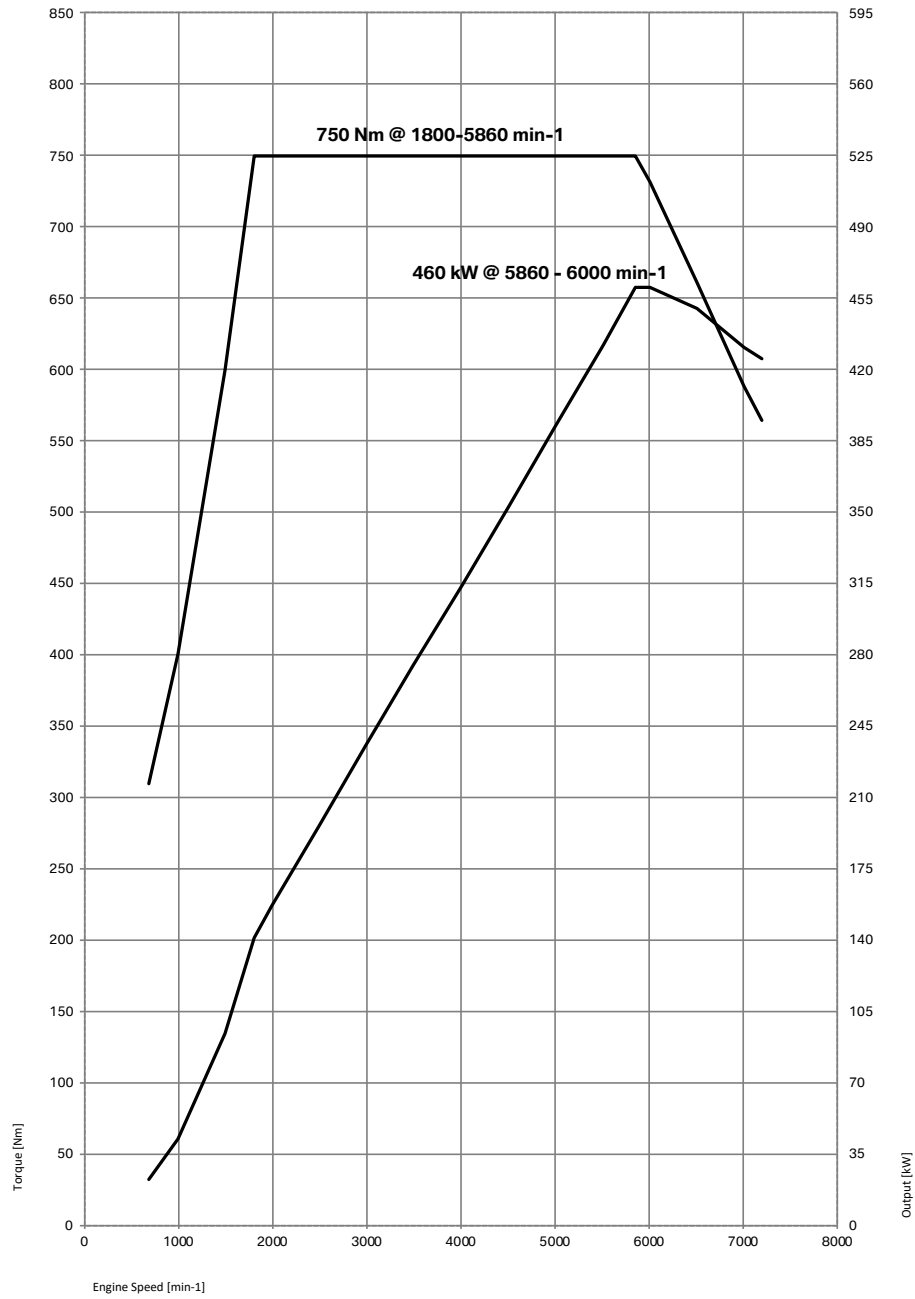

# Exterior and interior dimensions. The new BMW X5 M.

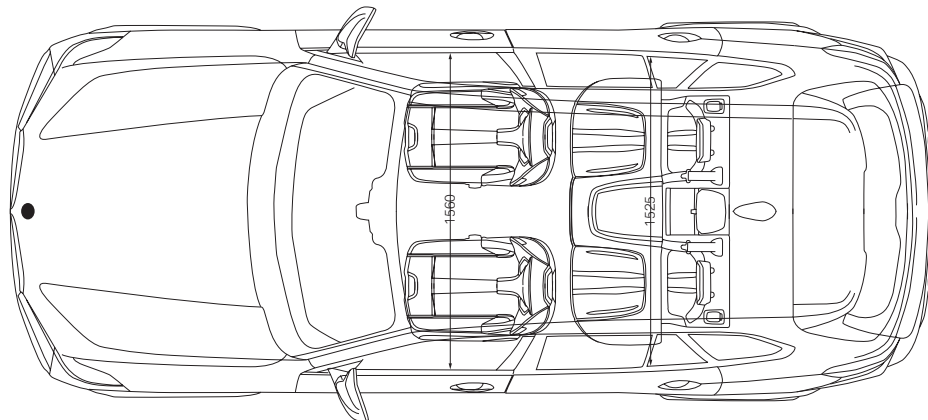
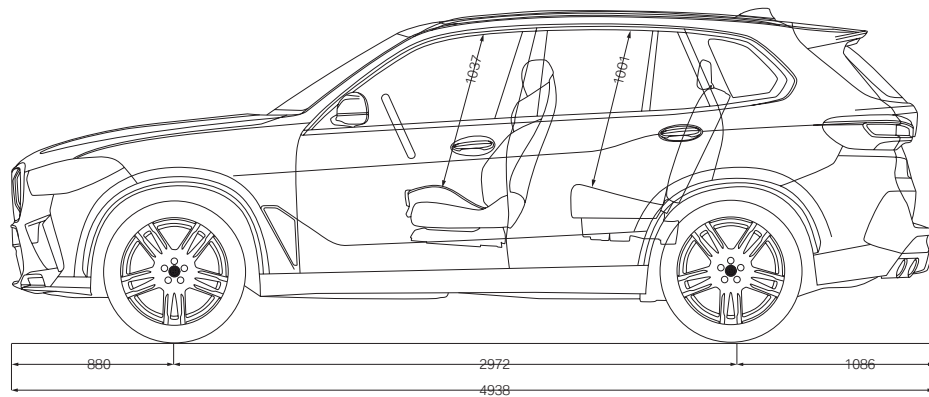
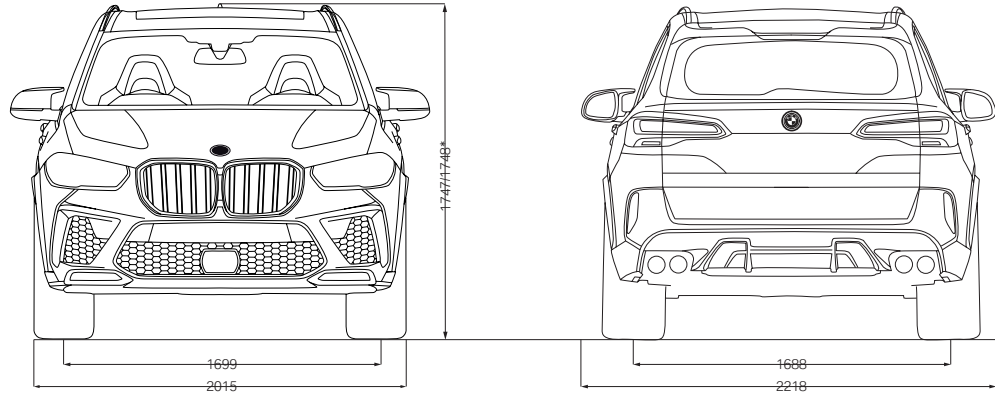

\* X5 M Competition